

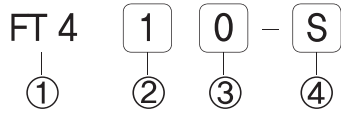

- ◆ 성능 및 내구성향상
- ◆ 파이롯트 타입
- ◆ 조작성 향상
- ◆ 무급유 타입

◆ 주문형식 표기방법



- ① 시리즈  
FT4 : FT410 시리즈 1/4  
FT5 : FT510 시리즈 3/8
- ② 절환방식  
1 : 5포트 2위치
- ③ 관 접속구경  
0 : PT  
1 : NPT
- ④ 복귀방식  
S : 싱글 복귀형

◆ 사양

	FT410	FT510
절환방식	5포트 2위치	
사용유체	공기 및 불활성 가스	
사용압력	0.15 ~ 1 Mpa	
유효단면적(mm <sup>2</sup> )	18.0	35.0
주위 및 사용유체온도	5 ~ 60° (41~ 140°F)	
급 유	불필요	
접속구경	1/4	3/8

◆ 통과유량

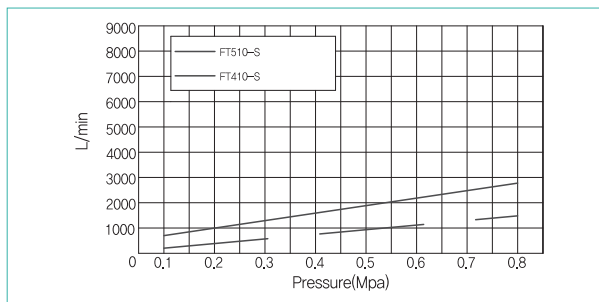

◆ 밸브형식

동작방식	모 델	절환방식	접속구경	유효단면적mm <sup>2</sup>
FT410-S	FT410-S	5포트 2위치 싱글	1/4	19.0mm <sup>2</sup>
FT510-S	FT510-S	5포트 2위치 싱글	3/8	35.0mm <sup>2</sup>

◆ 밸브 치수도

▶ 2위치 싱글

FT410-S

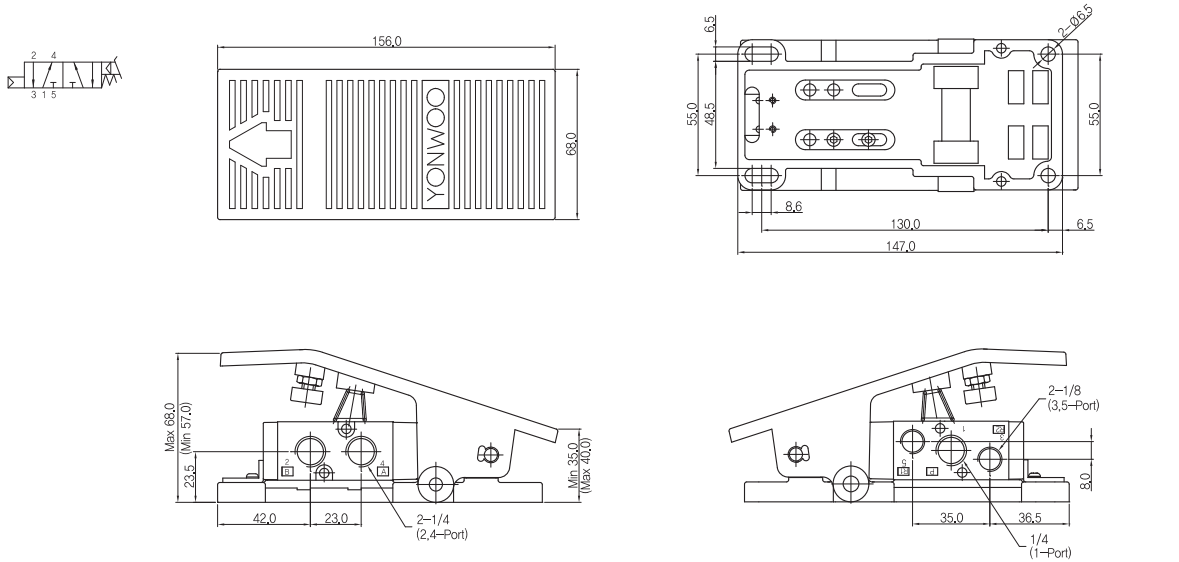

▶ 2위치 싱글

FT510-S

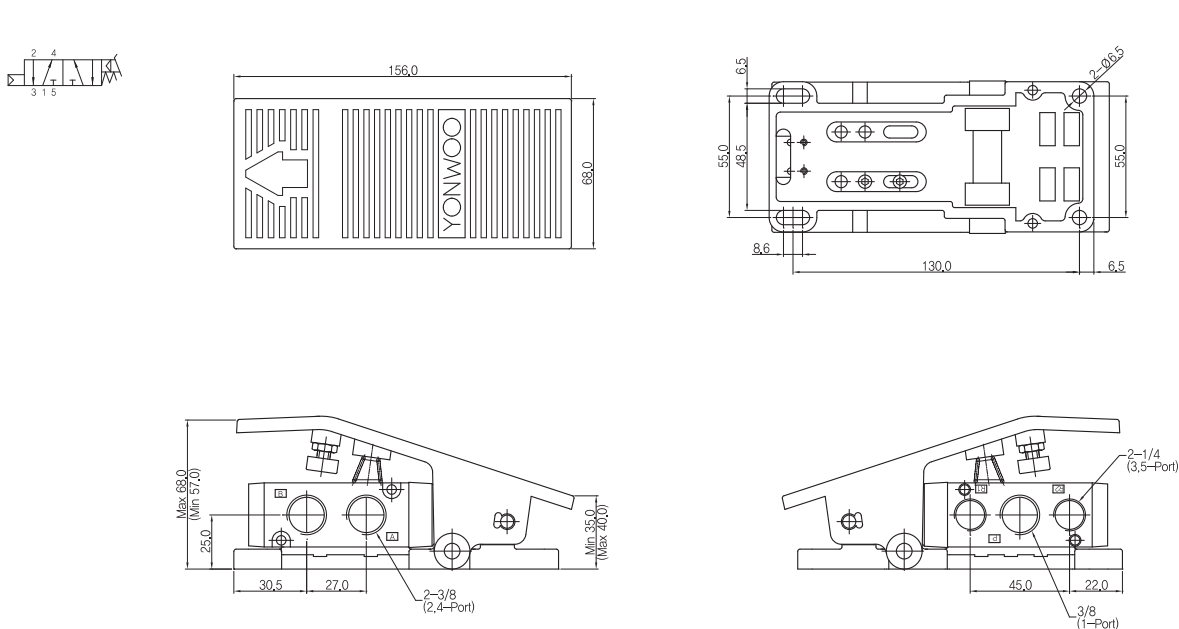

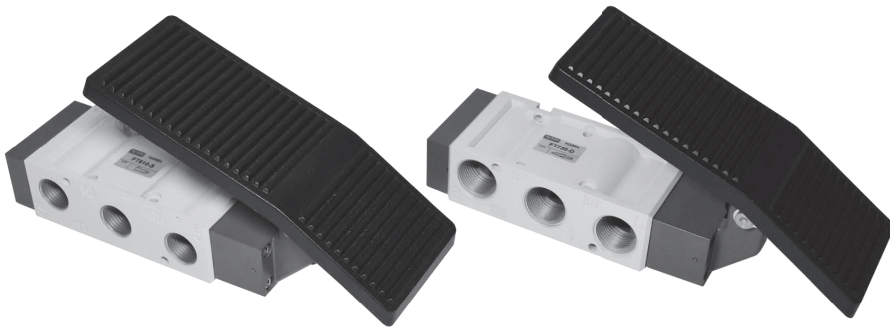

- ◆ 성능 및 내구성향상
- ◆ 직동식 타입
- ◆ 다양한 회로구성
- ◆ 조작성 향상
- ◆ 무급유 타입

### ◆ 주문형식 표기방법

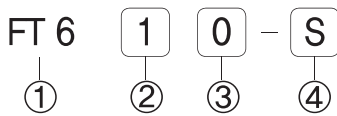

① 시리즈  
 FT6 : FT600 시리즈 1/2  
 FT7 : FT700 시리즈 3/4

② 절환방식  
 1 : 2위치 싱글  
 2 : 2위치 더블  
 3 : 3위치 Close Center  
 4 : 3위치 Exhaust Center  
 5 : 3위치 Open Center

③ 관 접속구경  
 0 : PT  
 1 : NPT

④ 복귀방식  
 S : 싱글 복귀형  
 D : 더블 정지형

### ◆ 사양

	FT600	FT700
절환방식	5포트 2위치, 5포트 3위치	
사용유체	공기 및 불활성 가스	
사용압력	0 ~ 1 Mpa	
유효단면적(mm <sup>2</sup> )	90,0	
주위 및 사용유체온도	5 ~ 60° (41 ~ 140°F)	
급 유	불필요	
접속구경	1/2	3/4

### ◆ 통과유량

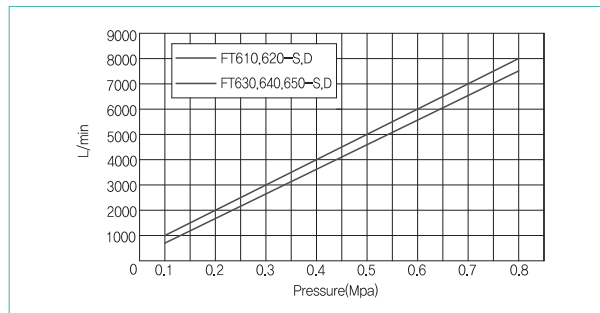

### ◆ 밸브형식

동작방식	모 델	절환방식	접속구경	유효단면적mm <sup>2</sup>
복귀형	FT610-S / FT710-S	5포트 2위치 싱글	1/2, 3/4	90,0mm <sup>2</sup>
정지형	FT620-D / FT720-D	5포트 2위치 더블		
복귀형	FT630-S / FT730-S	5포트 3위치 싱글		70,0mm <sup>2</sup>
	FT640-S / FT740-S	5포트 3위치 싱글		
	FT650-S / FT750-S	5포트 3위치 싱글		
정지형	FT630-D / FT730-D	5포트 3위치 더블		
	FT640-D / FT740-D	5포트 3위치 더블		
	FT650-D / FT750-D	5포트 3위치 더블		

◆ 밸브 치수도

▶ 2위치 싱글 / 2위치 더블

FT610-S

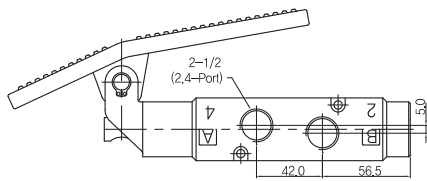
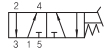

FT620-D

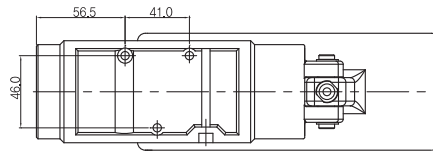
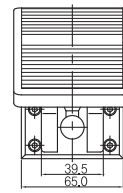
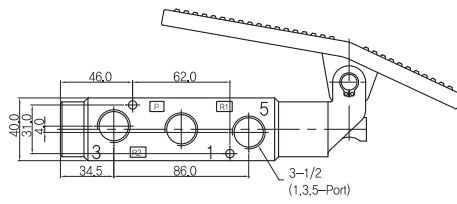
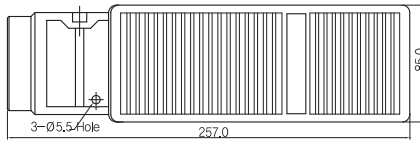

▶ 3위치 Close Center

FT630-S

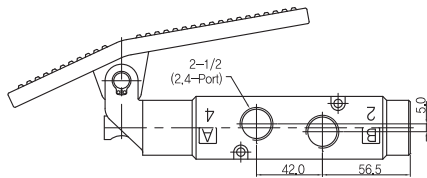
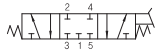

FT630-D

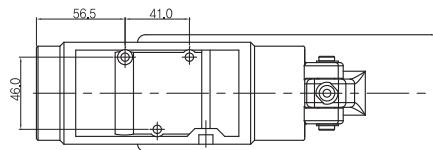
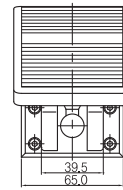
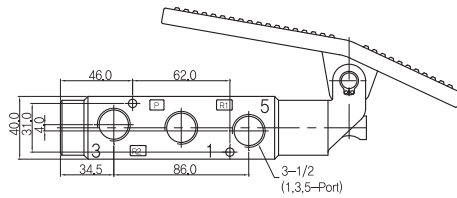
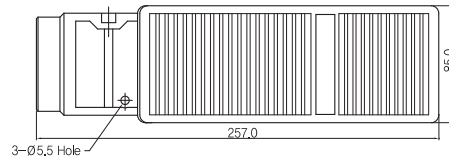
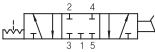

◆ 밸브 치수도

▶ 3위치 Exhaust Center

FT640-S

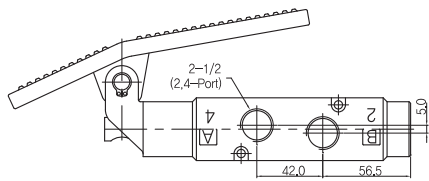
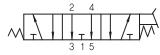

FT640-D

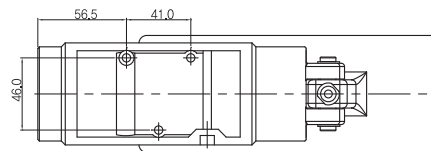
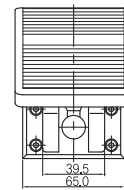
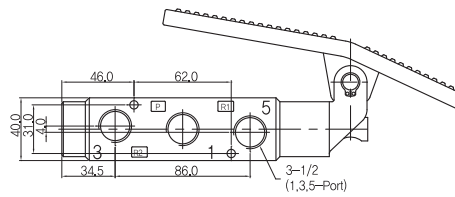
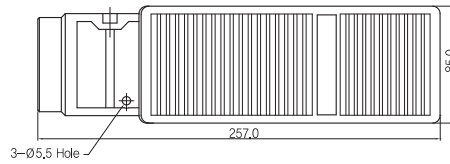
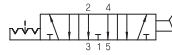

▶ 3위치 Open Center

FT650-S

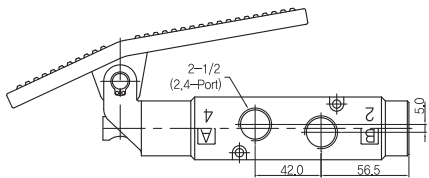
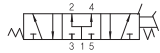

FT650-D

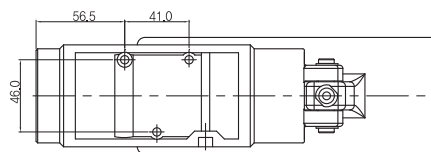
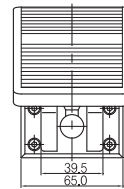
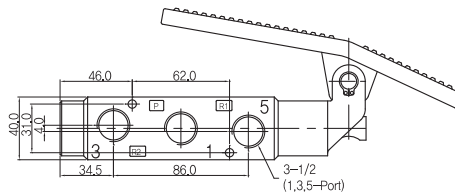
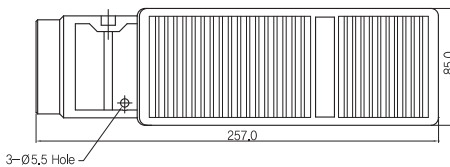
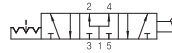

◆ 밸브 치수도

▶ 2위치 싱글 / 2위치 더블

FT710-S

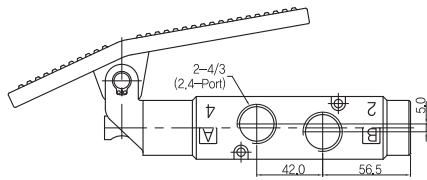
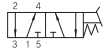

FT720-D

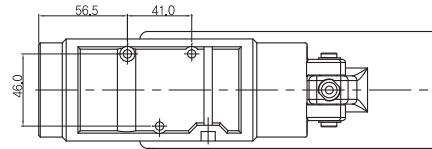
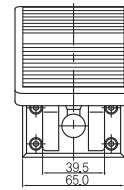
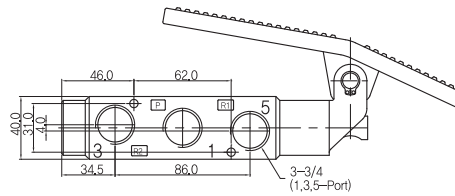
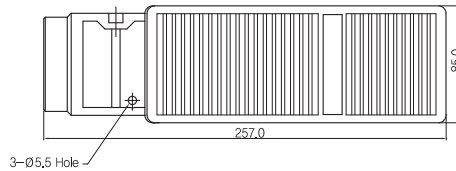
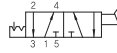

▶ 3위치 Close Center

FT730-S

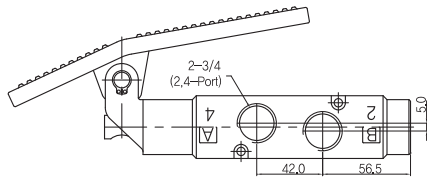
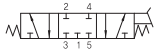

FT730-D

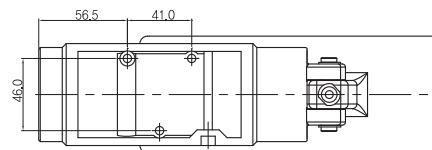
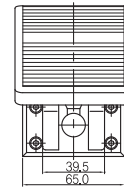
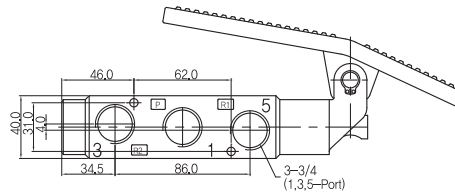
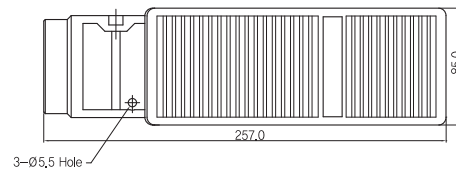
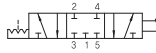

◆ 밸브 치수도

▶ 3위치 Exhaust Center

FT740-S

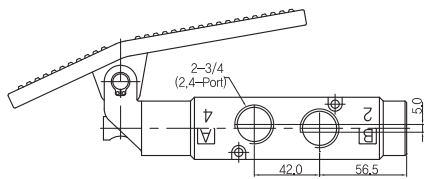
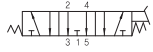

FT740-D

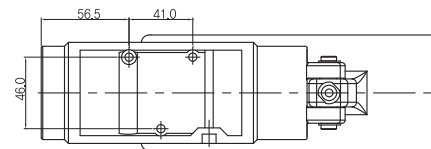
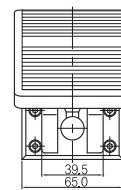
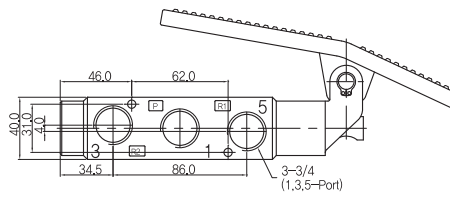
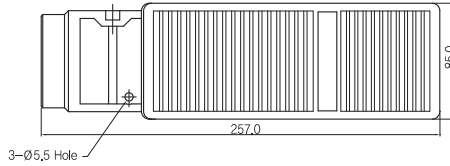
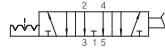

▶ 3위치 Open Center

FT750-S

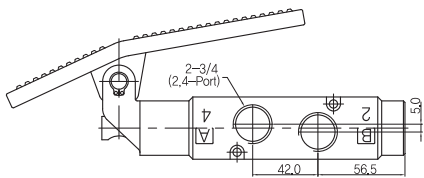
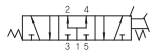

FT750-D

