

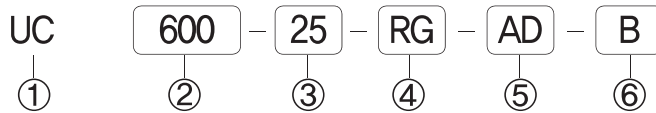

- ◆ 성능 및 내구성 향상
- ◆ 매립형 압력계이지
- ◆ 매뉴얼 드레인
- ◆ 오토 드레인
- ◆ 조립성 향상
- ◆ 금속 보호커버

◆ 주문형식 표기방법



① 사양

UC : 에어필터 + 레귤레이터+루브리케이터
 UFC : 에어필터레귤레이터+루브리케이터
 UFR : 에어필터레귤레이터
 UF : 에어필터
 UR : 레귤레이터
 UL : 루브리케이터

② 시리즈

600 : 유니트 600시리즈

③ 접속구경

20 : PT 3/4
 25 : PT 1

④ 부착기호

무기호 : 각형 매립 압력계
 NG : 압력계 없음
 RG : 돌출형 라운드 압력계

⑤ 드레인 형식

무기호 : 수동드레인
 AD : 오토드레인켓

⑥ UF, UL 브라켓 옵션

무기호 : 브라켓 제외
 B : 개별 브라켓 포함

◆ 표 준 사양

사용유체	공기
최고사용압력	1 Mpa
보증내압력	1.5 Mpa
설절압력범위	0.05 ~ 1 Mpa
사용온도	-5 ~ 60° (41~ 140°F)
여과도	5 μm
배기형태	릴리프형
권장사용유	ISO VG32(터빈유1종)
접속구경	3/4, 1

◆ 통과유량 그래프

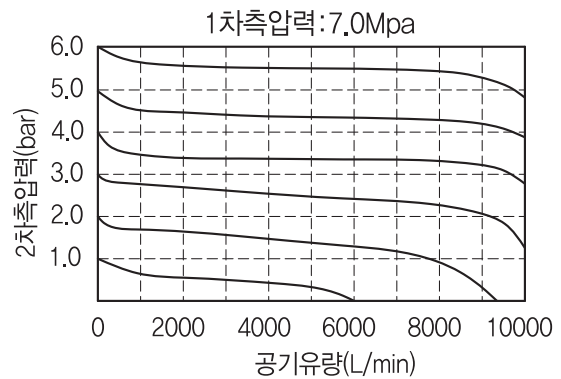

◆ F.R.L 치수도

▶ 필터 + 레귤레이터 + 루브리게이터

UC600-25-AD

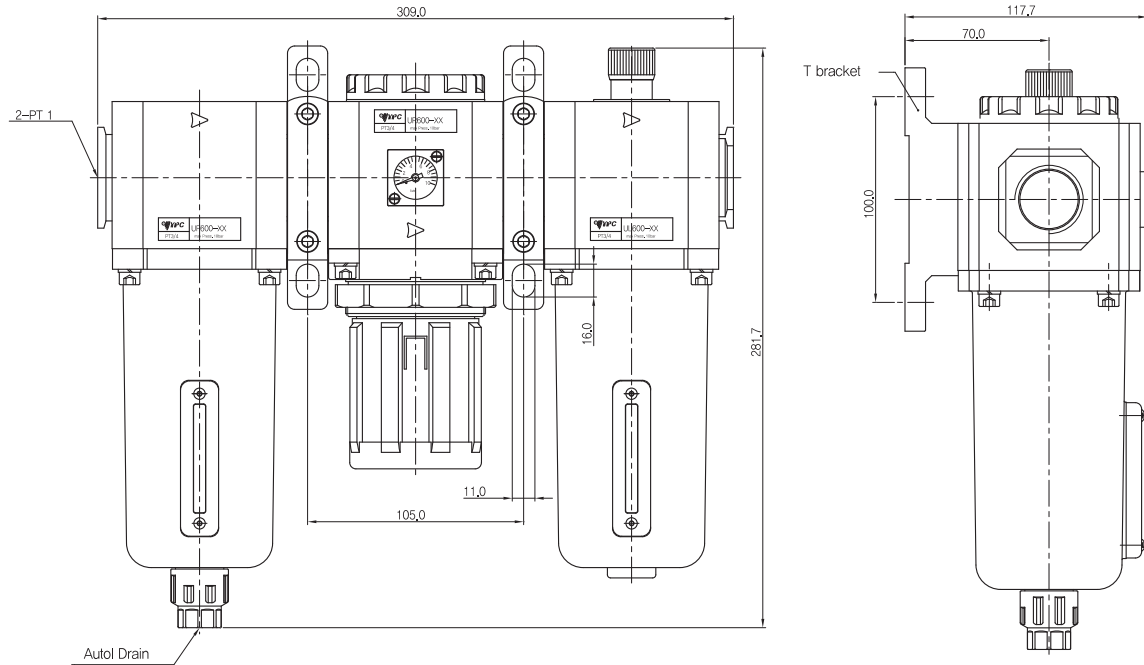

▶ 필터레귤레이터 + 루브리게이터

UFC600-20

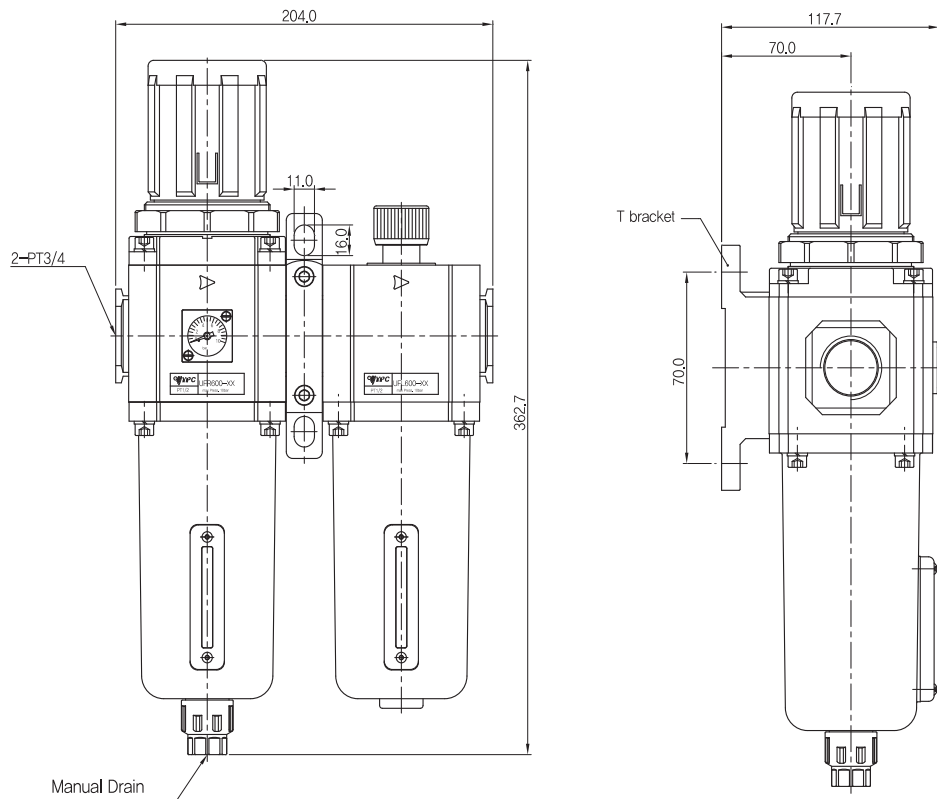

바른공기계

필터드라이어

바른공기계

필터드라이어

공기압축조기 UC600

◆ F.R.L 치수도

▶ 필터레귤레이터

UFR600-25-AD

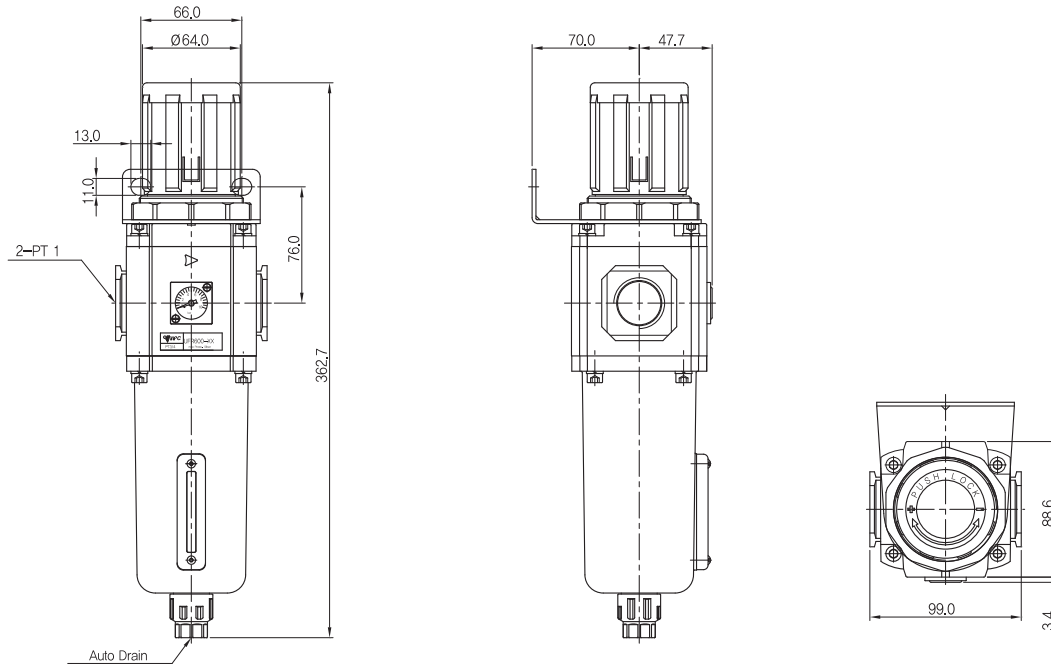

▶ 에어필터

UF600-20-B

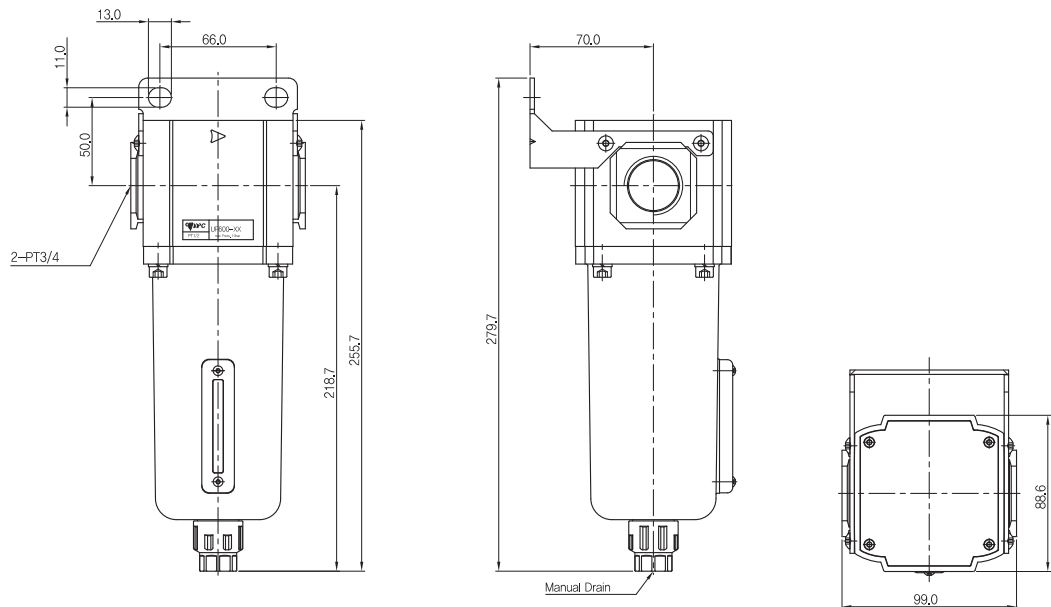

◆ F.R.L 치수도

▶ 레귤레이터

UR600-25

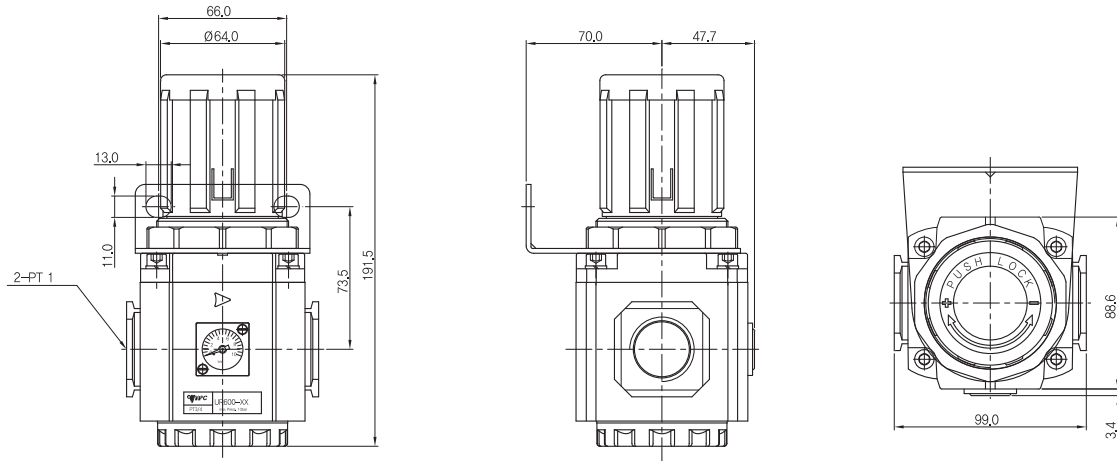

▶ 루브리게이터

UL600-20-B

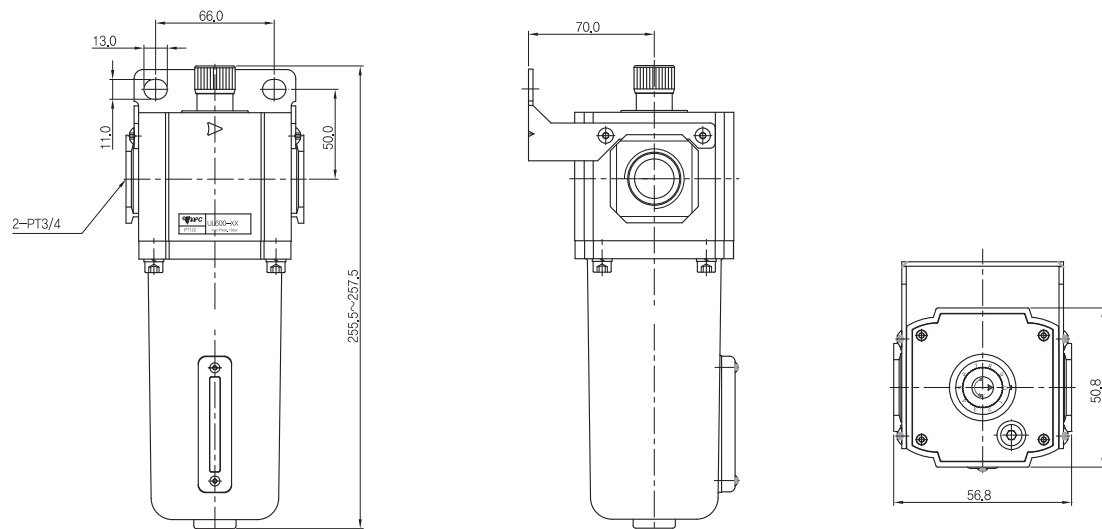

보관용

기밀용

보관용

기밀용

00900 | 니스오유닛

◆ 부속품 치수도

▶ 진압배기밸브

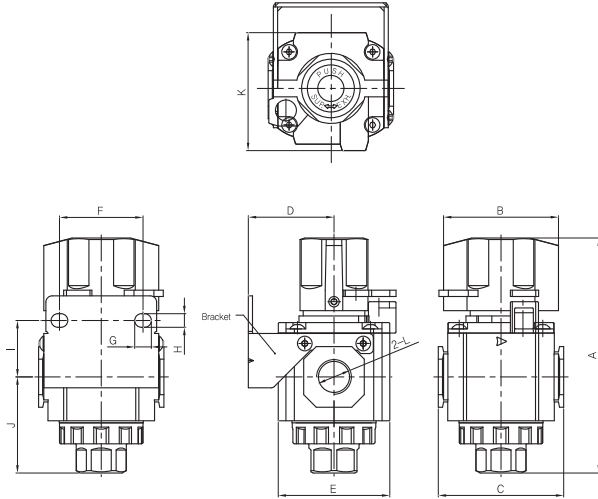

진압배기밸브

(mm)

시리즈	주문형식	A	B	C	D	E	G
U200	UZ200-08	89,0	42,0	47,0	30,0	40,0	27,0
U300	UZ300-10	112,5	55,0	60,0	41,0	53,4	40,0
U400	UZ400-15	134,0	65,0	75,0	50,0	64,0	55,0

시리즈	주문형식	G	H	I	J	K	L
U200	UZ200-08	8,4	5,4	23,0	36,5	42,6	G1/4
U300	UZ300-10	8,0	6,5	27,0	46,0	56,4	G3/8
U400	UZ400-15	11,0	8,5	33,5	58,5	66,0	G1/2

▶ 에어분배구

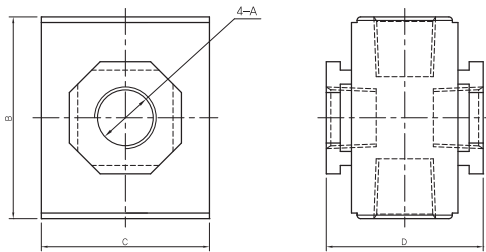

에어분배구

(mm)

시리즈	주문형식	A	B	C	D
U200	UA2-08	G1/4	36,0	30,0	28,3
U300	UA3-10	G3/8	44,0	38,0	35,0
U400	UA4-15	G1/2	52,0	52,0	52,0
U600	UA6-20	G3/4	76,0	68,0	60,0
U600	UA6-25	G1	76,0	68,0	60,0

▶ T-브라켓

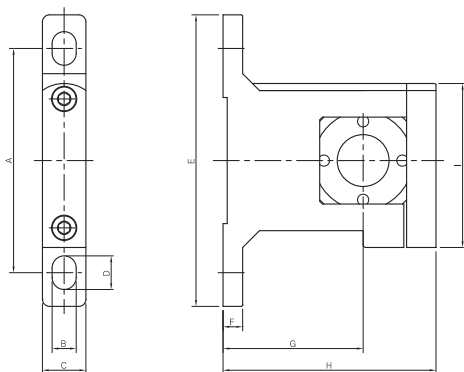

T-브라켓

시리즈	주문형식	A	B	C	D	E	F	G
U200	UT-2B	50,0	5,5	11,5	8,5	66,0	5,0	30,0
U300	UT-3B	70,0	6,5	12,5	9,0	88,0	7,0	41,0
U400	UT-4B	80,0	8,6	15,5	12,0	104,0	7,0	50,0
U600	UT-6B	100,0	11,0	19,5	16,0	128,0	7,0	70,0

(mm)

시리즈	H	I
U200	45,0	38,3
U300	60,5	49,3
U400	76,0	58,5
U600	104,0	79,5

◆ **부속품 치수도**

▶ **U-브라켓**

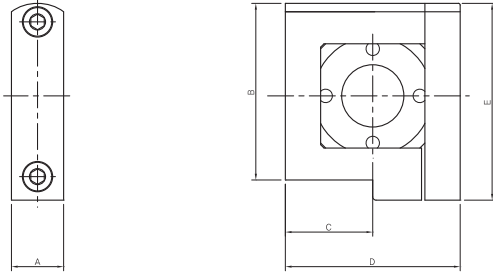

U-브라켓

시리즈	주문형식	A	B	C	D	E
U200	U2-B	11,5	35,3	15,0	30,0	38,3
U300	U3-B	12,5	43,8	19,0	38,0	49,3
U400	U4-B	15,5	52,5	26,0	52,0	58,5
U600	U6-B	19,5	76,5	34,0	68,0	79,5

▶ **개별브라켓 (UF, UL)**

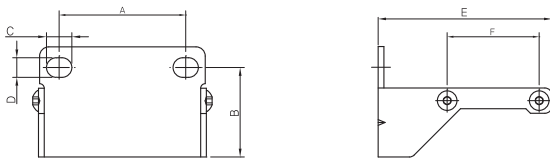

개별브라켓

시리즈	주문형식	A	B	C	D	E	F
U200	UFL-2B	27,0	33,0	8,4	5,4	44,8	20,0
U300	UFL-3B	40,0	44,0	8,0	6,5	59,8	28,0
U400	UFL-4B	55,0	48,0	11,0	8,5	75,5	40,0
U600	UFL-6B	66,0	51,0	13,0	11,0	104,0	54,0